

Maintain space for opening the manhole ~Ø400x400

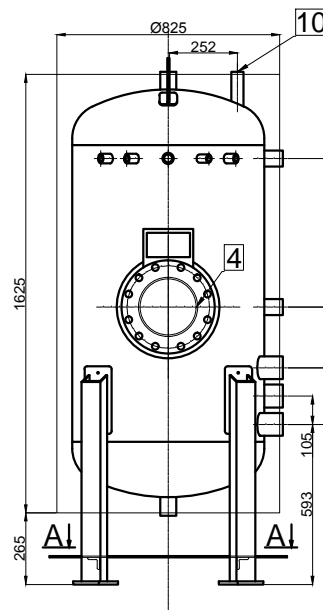

Maintain space for demontage of heating elements ~600x400x300

Maintain space for demontage of heating elements ~600x400x300

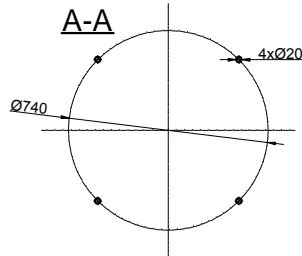

# BLACK STEEL 4 LEGS TANK ELECTRIC HEATER Ø712 V=500[L], p=0,8[MPa]

Technical Data Dane Techniczne Технические характеристики		Item L.p. Номер	Name of connection Nazwa połączenia Название соединения	DN
Working pressure Ciśnienie pracy Рабочее давление	8 [bar (бар)]	1	Hot water outlet Wylot ciepłej wody Выход горячей воды	G 1½" <F>
Working temperature Temperatura pracy Рабочая температура	65 [°C]	2	Thermometer Termometr Термометр	G ¾" <F>
Nominal volume Pojemność nominalna Номинальный объем	0,5 [m³ (м³)]	3	Thermostatic sensor Czujnik termostatu Термостатический датчиком	G 1" <F>
Medium Medium Медиум	Water Woda Вода	4	Manhole Wiaz rewizyjny Люк	DN 200 PN 16
Weight empty / operating Waga zb. pust. / robocza Вес пустой / рабочий	250/750 [kg (Kr)]	5	Cold water inlet/Drain Wlot zimn. wody/Drenaż Дренаж/Впуск холодной воды	G 1½" <F>
Design rules Zasady projektowania Принципы проектирования	Det Norske Veritas Edi 2012 EN 13445	6	Manometer Manometr Манометр	G ½" <F>
Material Materiał Материал	Black Steel Czarna stal черной сталь	7	Thermostat Termostat Термостат	G ¾" <F>
Surface treatment Obróbka powierzchniowa Поверхностная обработка	Galvanized and painted Ocynkowany i pomalowany Оцинкованный и окрашенный	8	Heating elements Grzałki Нагревательный элемент	G 2" <F>
		9	Hot water inlet Wlot ciepłej wody Впуск горячей воды	G 1½" <F>
		10	Zinc Anode Anoda cynkowa Анод	G 1" <F>
		11	Support for control panel Mocowanie skrzynki Монтаж	G 1½" <F>

Doe sp. z o.o.  
ul. Sibeliusa 3  
81-015 Gdynia, Poland  
NIP: 9580651261

T: +48 58 6236145  
F: +48 58 6643737  
E: doe@doe.pl  
www.doe.pl

## SEAL BG 500

Date: 12-10-2015

PZ594-R

Sheet: 1/1

This documentation is property of DOE Sp. z o.o. and all information in it contained can not be reproduced, utilized, revealed, transmitted or made public in any other way without previous written authorization from the owner. Any other person in possession of the document recognises its obligation of treating it as confidential.