



water

Contact details:

Meeting and correspondence address:
DOE Sp. z o.o.,
Al. Parku Krajobrazowego 84,
84-207 Łężyce, Poland

Tel. +48 58 6643210
Fax. +48 58 6643737

Email: doe@doe.pl

Registration and invoicing address:
DOE Sp. z o.o.,
Sibeliusa 3
81-015 Gdynia, Poland

Visit our web page:
www.doe.pl

Date of establishment: 1992

Local representative details:

doe[®]
Est. 1992

TANKS
HYDROPHORE SYSTEMS
SHARK - TURTLE - DOLPHIN

Designed and made in Poland



APPLICATION

TURTLE

- store the fresh water
- store the sanitary water
- store the salt water
- boosting the water
- maintain the pressure of the water

SHARK

- store all kinds of water

DOLPHIN

- store the compressed air
- store working air
- store control air

CERTIFICATION

Our services include proper handling the certification process.
We have made tanks with various marine class certification like:
DNV-GL, BV, LLOYD, ABS, RINA, ASME, U-STAMP, RRR, RMRS
and others.

In order to make things simpler and quicker, we decided to make a
type approval under RRR class and we are approved by DNV-GL as
Approved Manufacturer of tanks class II.

ADVANTAGES

- Huge database of ready, approved, marine drawings
- Quick contact, flat office organization = quick decisions
- Skids can be made according to the client's documentation
- Technical help and suggestions from DOE side
- Different pump types and manufacturers possibility
- 3D and dwg drawings of complete skids are supplied after the order
- Quick tank manufacturing time
- 25 years of experience in worldwide logistics and marine business
- Approval for II class tank manufacturing by DNV-DL
- Type approved by Russian River Register



DOE is approved for the
Manufacture of Welded Pressure
Vessels, Class II
by DNV-GL



WATER tanks

Water tanks, with capacity range from 100 to 3000 litres. Bigger on demand up to 30.000 litres. Most of the marine certificates possible.



- capacity from 100 to 3000 litres
- designed pressure: 10 bar
- working pressure: 8 bar
- test pressure: 15 bar
- extra ports and inspection openings are plugged
- working temperature: 5 to 50°C
- all connections are BSP inside threaded
- extra option: all connections flanges
- hot zinc galvanized
- water level indicator included
- material: black steel or 316L stainless steel

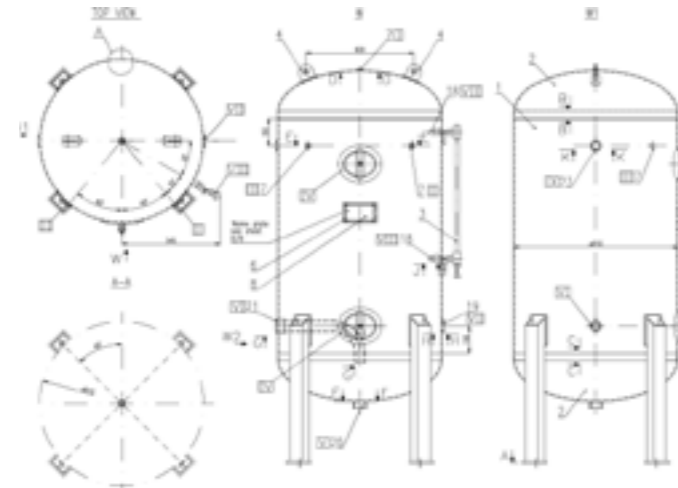

HYDROPHORE units

Skid mounted unit with marine water pumps, electric box, piping and regulation panel (manometers, presostats, safety vales)



- all mounted on common skid
- two pumps working separately
- Most well-known pump producers possible
- 3 x 400V 50Hz or 3 x 440V 60Hz
- aluminium or stainless steel skid
- all connected electrically and hydraulically
- pressure tested
- stainless steel piping
- metal electric box in standart with full redundancy
- 4 manometers, 1 presostat and safety valve in standart
- safety valve included

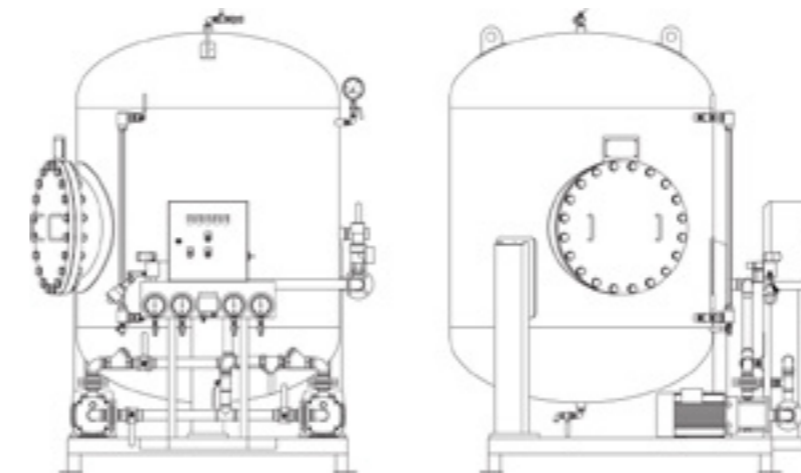

WORKING AIR tanks

Air tank, with capacity range from 100 to 3000 litres and pressure up to 15 bar. Bigger on demand up to 30000 litres. Most of the marine certificates possible.



- capacity from 100 to 3000 litres
- designed pressure: 11 bar
- working pressure: 10 bar
- test pressure: 16 bar
- extra ports and inspection openings are plugged
- working temperature: -10 to 50°C
- all connections are BSP inside threaded
- extra option: all connections flanges
- standard blue color (any other color on demand)
- material: black steel or 316L stainless steel

